

Mock Examination Paper

Full Mock Paper 1

- 1** When on a boat afloat about a kilometre outside the low water line (or baseline) MM0ABC should identify as
1A2, 1A5
- A MM0ABC/MM
 - B MM0ABC/M
 - C M0ABC/MM
 - D M0ABC/M
- 2** A person who holds a UK Radio Amateurs' Examination Pass Certificate but who has not yet applied for a licence requests to operate the club station under supervision. To comply with the licence you must check that they
1B1, 1B2
- A are a UK citizen.
 - B are aged 18 or over.
 - C are not a disqualified person.
 - D have an UK passport as identification.
- 3** Which of the messages below is not permitted by the amateur licence?
1C1, 1C2
- A A message consisting mostly of Q codes which may not be in common amateur use.
 - B A message using the names of colours to describe circumstances known to the recipient.
 - C A message sent on an FM voice channel using audio tones for Morse code.
 - D A message in an uncommon foreign language that is not widely understood.
- 4** Amateur transmitting equipment must be constructed such that
1D1
- A no more than 1% of the transmitted power falls outside the nominal modulated carrier bandwidth.
 - B no more than 1% of the transmitted power falls outside the frequency band.
 - C unwanted emissions are suppressed to the level as defined in Interface Requirement IR 2028.
 - D unwanted emissions are suppressed to no more than 0.5% each side of the occupied bandwidth.

- 5**
1E2
- If an internet connection or telephone line is used to provide the link to a remotely controlled transmitter then
- A the link must not be encrypted.
 - B the link must be encrypted.
 - C the use of the link must be consistent with the terms and conditions of the service provider.
 - D the use of the link must comply with the terms and conditions of the amateur licence.

- 6**
1F1, 1F2
- When operating in international waters in the southern hemisphere, the frequencies you should use are given in the
- A schedule to the amateur licence for the nearest country.
 - B schedule to your UK licence provided they are also an allocation in that ITU region.
 - C allocation to amateurs in the ITU region concerned.
 - D just the schedule to your UK licence provided you remain in international waters.

- 7**
11G1, 1G2
- When operating on 5MHz
- A the maximum transmitted bandwidth must not exceed 6kHz for any type of modulation.
 - B the location of the station shall be given every 30 minutes to an accuracy of at least 5km.
 - C the station shall be identified at no more than 15 minute intervals.
 - D the licensee must be contactable by telephone in the vicinity of operation.

- 8**
2B1
- What is the resistance looking in to the ladder network of resistors shown?

All values are in ohms.

- A 25 Ω
- B 50 Ω
- C 100 Ω
- D 200 Ω

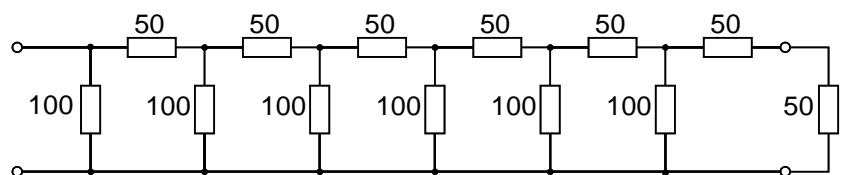

- 9**
2D1, 2D2, 2D3
- One factor that should be considered when selecting capacitors in a VHF transmitter for use by Foundation licensees is the
- A breakdown voltage.
 - B choice of dielectric.
 - C harmonic distortion.
 - D tuning range.

- 10**
2D4
- The back EMF in an inductor will
- A enhance a change in current through it
 - B oppose a change in current through it
 - C maintain a current through it
 - D limit a current through it.

- 11**
2D7
- The diagram shows an RC circuit and a graph showing time from switch-on on the X-axis. The Y axis of the graph should be marked

- A voltage across C
- B charge on C
- C time constant
- D voltage across R

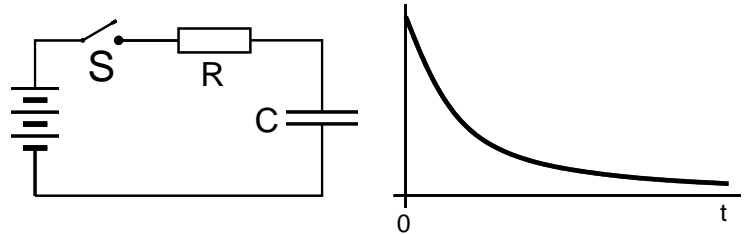

- 12**
2E3, 2E4,
2E5, 2E6
- What is the function of C3 in the circuit diagram?
- A decoupling
 - B smoothing
 - C coupling
 - D blocking

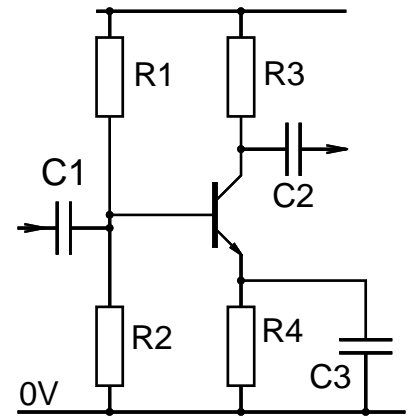

- 13**
2F1, 2F2
- The Fourier Transform is a
- A process by which analogue signals may be sampled for further processing.
 - B process by which digital signals may be sampled for further processing.
 - C mathematical process to convert time domain data to frequency domain data.
 - D mathematical process to convert frequency domain data to time domain data.

- 14**
2G1
- A power supply for a transmitter is rated at 13.8V 25A continuous. What current will be required from the 230V mains supply if the power supply itself is 80% efficient?
- A 1.2A
 - B 1.5A
 - C 1.9A
 - D 2.2A

- 15** An antenna for 14MHz shows a feed capacitance of 140pF. What value of inductor is required to bring the system to resonance?
 2H1, 2H2, 2H4, 2H5
- A 0.92 μ H
 - B 1.9 μ H
 - C 2.9 μ H
 - D 3.7 μ H

- 16** What component exhibits the characteristic curve shown in the diagram?
 2I1, 2I3
- A Field effect transistor.
 - B Zener diode.
 - C PNP transistor.
 - D NPN transistor.

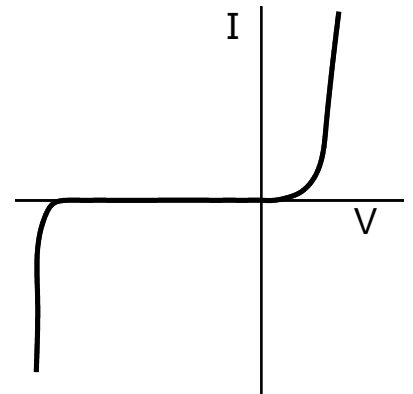

- 17** What configuration is the transistor circuit shown in the diagram?
 2I6

- A Common emitter.
- B Common gate.
- C Common source.
- D Common drain.

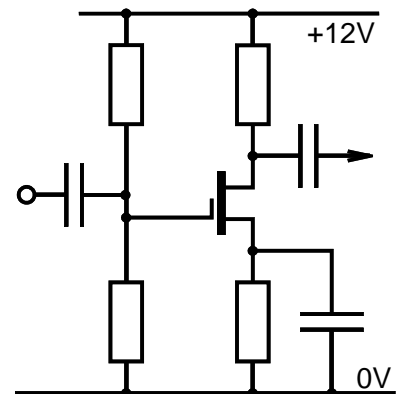

- 18** What feature or requirement would you expect of a good quality switch mode power supply?
 2J2, 2J3, 2J4
- A Filters on the input and output.
 - B Adequate heatsink on the series pass transistor.
 - C Heavy due to a substantial iron cored transformer.
 - D Option of 230/115V windings on the mains transformer.

- 19** A transmitter utilises a balanced mixer to produce an SSB signal at 12MHz. To obtain an output at 144MHz the transmitter would
 3A1, 3B1
- A mix the signal with an oscillator output at 144MHz.
 - B use a frequency tripler followed by two frequency doublers.
 - C mix the signal with another signal at 156MHz.
 - D feed the signal to a non-linear amplifier with a tuned collector load at 144MHz..

- 20**
3C1 A 2m satellite transmitter is centred on 145.9875MHz with an occupied bandwidth of 12kHz as specified in the band plan. What is the maximum tolerance in parts per million (ppm) of the oscillator error to avoid out-of-band radiation?
- A 45ppm
 - B 3.5ppm
 - C 86ppm
 - D 7ppm
- 21**
3C2, 3C3 Which type of frequency source requires a table of the amplitude of a sine wave over the 360-degree cycle?
- A A crystal oscillator.
 - B A frequency synthesiser.
 - C Direct digital synthesiser.
 - D Beat frequency oscillator.
- 22**
3D13E1,
3E2 A UHF FM transmitter is set up to operate at 433MHz with a peak deviation of 5kHz. The maximum audio frequency is 3.5kHz. The bandwidth of the transmission will be approximately
- A 7kHz.
 - B 10kHz.
 - C 17kHz.
 - D 25kHz.
- 23**
3F2, 3F3,
3F4, 3F5 Which of the following modes of transmission will cause the greatest heat dissipation in the power amplifier if the PEP outputs are the same?
- A AM
 - B FM
 - C CW
 - D SSB
- 24**
3G1, 3G2,
3G3, 3G4,
3G5 An SSB transmitter is correctly operating at 7.050MHz but is a little over-modulated by an audio voice signal. There is a consequent risk of unwanted transmissions around
- A 7.045MHz
 - B 7.065MHz
 - C 14.050MHz
 - D 14.100MHz

25 In the block diagram of a single superhet, what is the function of the block marked 'X'?

3H3, 3I1

- A Frequency synthesiser
- B Beat Frequency Oscillator
- C Detector
- D Second Local Oscillator.

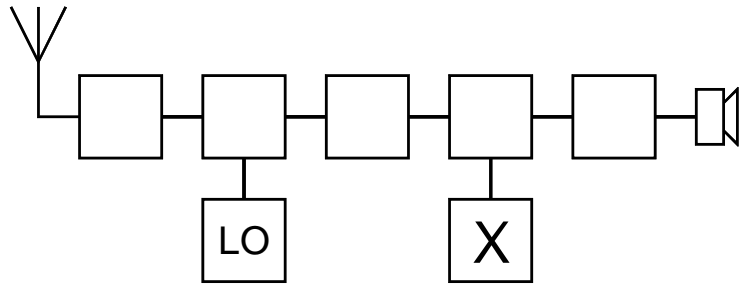

26 A receiver initially picks up the wanted signal on 7.1MHz and again, weakly, when tuned to 8.7MHz. It is likely the local oscillator is now on a frequency of

3I2, 3I3,
3I4, 3I5

- A 7.1MHz
- B 7.9MHz
- C 8.6MHz
- D 15.8MHz

27 It is noticed that adding a preamp to a VHF transceiver allows more weak signals to be received but adding a similarly specified preamp to an HF receiver results in no noticeable improvement. Why might that be so?

3J1

- A There is a lot more RF noise at VHF than at HF and the preamp is able to reduce the noise in comparison to the wanted signal.
- B Propagation at VHF does not suffer losses in the ionosphere, so VHF signals are naturally stronger and better able to overcome the background RF noise.
- C There is more natural RF noise at HF, so an HF preamp only makes both the RF noise and signals stronger without improving the signal to noise ratio.
- D It is easier to produce low noise amplifiers at VHF than HF so the additional noise contribution from the preamp is reduced.

28 The AGC control signal is normally derived from the

3K1, 3L1

- A RF amplifier output signal.
- B audio signal from the demodulator.
- C IF Amplifier output level.
- D Wanted output from the mixer.

29
13M1, 3M2

The drawing shows the 'constellation diagram' of a data modulation scheme. The dots represent the heads of the vectors that different data symbols may occupy. Which statement below correctly describes the data system?

- A All the vectors have the same amplitude.
- B The system is frequency modulated.
- C The vector positions are at 90 degree intervals.
- D The diagram is an example of QPSK modulation.

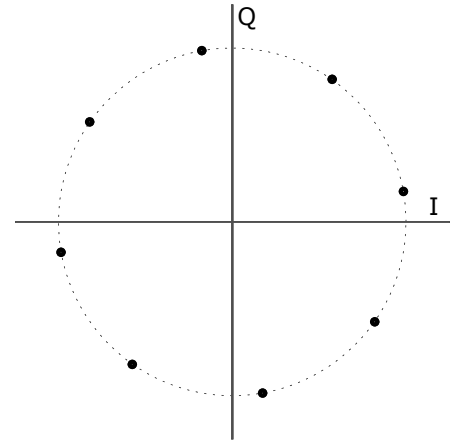

30
3N1, 3N2

The RIT control is likely to be of use when

- A setting up a data contact.
- B holding a QSO on 2m FM.
- C taking part in an SSB net.
- D notching out a continuous tone.

31
4A3, 4B1

The balun shown in the diagram is a

- A sleeve balun.
- B 4:1 balun.
- C $\lambda/4$ balun.
- D choke balun.

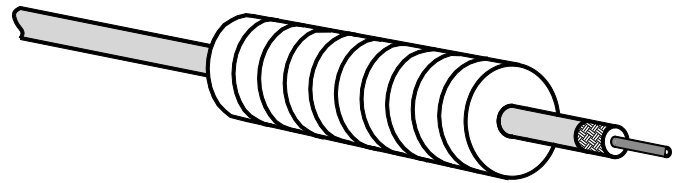

32
4D1, 4D2

Which drawing correctly shows the current and voltage distribution on a correctly fed quarter wave ground-plane antenna? (Further from the antenna denotes a greater value.)

- A Drawing 1
- B Drawing 2
- C Drawing 3
- D Drawing 4

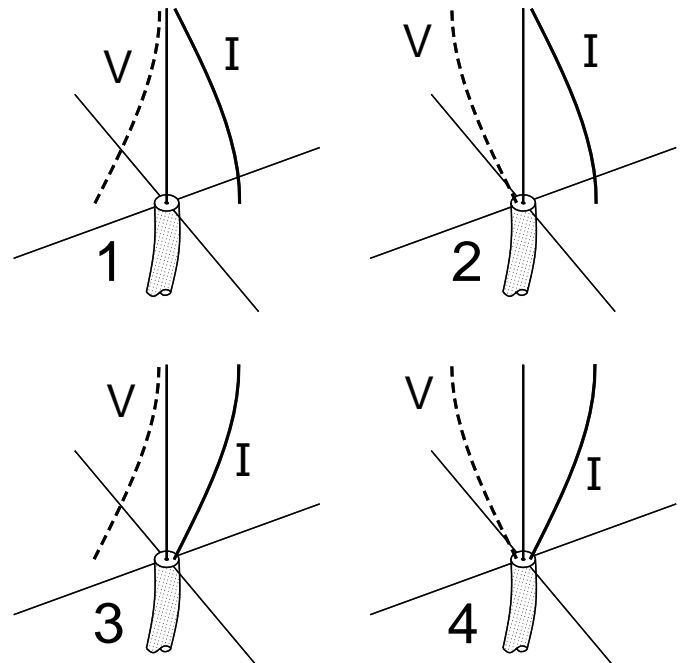

- 33** A power meter shows that 100W is being fed to the antenna but that 50W is reflected.
The VSWR is about
- 4E1, 4E2,
4E3
- A 1.4:1
 - B 2:1
 - C 4:1
 - D 6:1

- 34** The circuit diagrams shows
- 4F1, 4F2
- A an antenna matching unit.
 - B an anti-alias filter for SDR.
 - C an HF band selection filter.
 - D a coax to dipole balun.

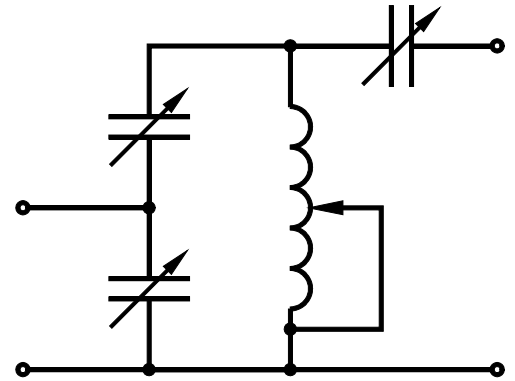

- 35** The statement that a radio wave is right-hand circularly polarised describes an electromagnetic wave where the E and H fields are at right-angles
- 5A1, 5A4
- A rotating with the E field leading by ninety degrees.
 - B rotating with the H field leading by ninety degrees.
 - C and rotates in a clockwise direction when viewed from behind.
 - D and rotates in a clockwise direction when viewed from the front.

- 36** The maximum usable frequency is
- 5B1, 5B2,
5B3, 5B4
- A usually within about 10% of the critical frequency
 - B lower than the critical frequency but dependent on the actual path length
 - C higher than the critical frequency and increases as the path length increases
 - D higher than the critical frequency and decreases as the path length increases.

- 37** A mode of propagation known as EME requires
- 15C3, 5D1,
5D2
- A relatively low power for line of sight communication.
 - B high gain antennas to help combat path loss.
 - C FM modulation to overcome frequency changes due to Doppler shift.
 - D horizontal polarisation to minimise reflection losses.

- 38** Poor installation of domestic radio and TV devices
- 6A2
- A should not have any significant effect on equipment meeting the EMC regulations.
 - B is likely to result in poorer performance and increased risk of suffering interference.
 - C should not have much effect on the operation of double insulated devices since there is no earth connection.
 - D is a breach of the approval requirements and should not normally occur.

- 39**
6A4
- A domestic radio receiver appears particularly sensitive to interference yet otherwise works as expected. This may well be because
- A all the broadcast radio signals are rather weak.
 - B the radio is an import and not made to European standards.
 - C it is more than a year old and out of warranty.
 - D the batteries need replacing more frequently.

- 40**
6B1, 6B2,
- A broadcast transmission is suffering interference such that the unwanted interferer can also be heard in addition to the wanted signal. This effect may be due to
- A cross-modulation in the RF stages.
 - B blocking in the receiver IF stages.
 - C capture effect in the FM discriminator.
 - D non-linearities in the loudspeaker.

- 41**
6C1, 6C2
- A neighbour's son has a CD player and audio amplifier in his room and is complaining that an amateur is causing interference. This
- A cannot be the fault of the amateur because no radio receiving device is present
 - B is just hard luck; the rules only protect licensed radio users so the amateur should do nothing
 - C is possibly caused by pickup in the loudspeaker leads.
 - D is likely to be direct pickup in the CD head.

- 42**
6C3, 6C4
- A transmission on top-band (160m) is found to cause interference to a domestic medium wave radio. A likely reason for this is
- A image channel interference
 - B breakthrough into the RF stages of the radio
 - C breakthrough into the IF stages of the radio
 - D an unwanted harmonic of the transmission.

- 43**
6D2
- The device shown in the diagram
- A is a combined balun and harmonic filter
 - B will provide impedance matching on HF
 - C is connected in the mains supply to radio equipment
 - D will cut the power in the event of a fault.

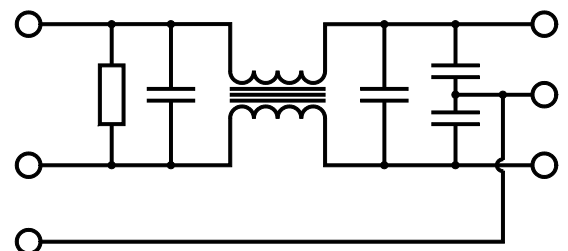

- 44**
6E1
- What action will best minimise the risk of causing EMC problems to your home and the neighbours.
- A Use the opposite polarisation to that of TV antennas in the neighbourhood.
 - B Avoid pointing the beam at the nearest neighbour.
 - C Stick to SSB in the evenings when TV viewing is likely.
 - D Use the minimum power needed to maintain each contact.
- 45**
6E2, 6E3
- An amateur has installed his HF transmitter in an upstairs bedroom with a coaxial cable through the loft out to and end fed antenna. On transmit it is noticed that
- A it is particularly difficult to achieve a low SWR.
 - B the case of the transmitter is almost painful to touch.
 - C incoming signals appear excessively prone to fast fading.
 - D the CW sidetone pitch can change by about 100 Hz.
- 46**
6F1, 6F2
- Unless the vehicle manufacturer specifies otherwise the best way to power an amateur transceiver is to
- A connect both the positive and negative leads direct to the vehicle battery.
 - B connect both the positive and negative leads via fuses direct to the vehicle battery
 - C connect the positive lead via a fuse direct to the vehicle battery and negative to the adjacent chassis connection.
 - D connect both the positive and negative leads to the car fuse panel ensuring the connection is to a permanently live power source.
- 47**
6G1
- A neighbour advises that his new digital television is suffering interference. You should
- A advise that amateur transmissions can affect analogue equipment but not digital and he should contact the supplier
 - B give the neighbour a copy of the TV interference leaflet from the RSGB EMC committee web site
 - C suggest he contacts Ofcom to get his installation arrangements properly checked
 - D ask if you can try out some test transmissions to see if it is likely to be your equipment.
- 48**
7A1
- You are trying to reply to a distant station on an island that you have wanted to contact for some time. Several stations are trying to contact him but all you get from that station, despite many calls, is 'listening five up'. What does that mean?
- A You should increase your transmit frequency 5Hz in order to correctly 'net' with him for clear speech.
 - B You have five other callers ahead in the queue, please wait your turn to call him.
 - C He is listening for callers about 5kHz higher in frequency, call him there for a contact.
 - D He will be moving up about 5kHz to get out of excessive QRM which is making contacts very difficult.



- 49**
7B1, 7B2,
7H1
- You hear an American station calling CQ on 7.205MHz LSB and wish to have a contact. You should
- A reply on 7.205MHz and hold a conversation.
 - B reply on 7.205MHz and suggest a different working frequency.
 - C reply on 7.2MHz and hope he nonetheless hears you.
 - D listen round to find a clear frequency before replying on his frequency.
- 50**
8A1, 8A2,
8A6
- A particular feature of equipment using valves that you should take careful note of is that valves
- A can get quite hot and risk causing a burn on exposed skin.
 - B are plugged in and can easily get partially loose causing difficulties.
 - C normally run at high voltages which could cause serious injury.
 - D are evacuated glass components which are quite fragile.
- 51**
8D1, 8E1
- A frequent but significant risk when thunderstorms are in the vicinity is
- A considerable increase in RF background noise levels and static crashes.
 - B high static charges on antennas which may damage electronic equipment.
 - C loss of electrical power which is particularly irritating in a contest.
 - D a poorer SWR due to static charges on the antenna and feeder.
- 52**
8F4, 8F5
- The ICNIRP provides recommendations on
- A the safe levels of RF exposure
 - B immunity to RF interference
 - C lightning protection of antenna
 - D amateur operating procedures.

53 Where should a fire extinguisher be located in relation to fuel storage and generator on a field day camp site?
8F6, 8F7

- A Position 1
- B Position 2
- C Position 3
- D Position 4

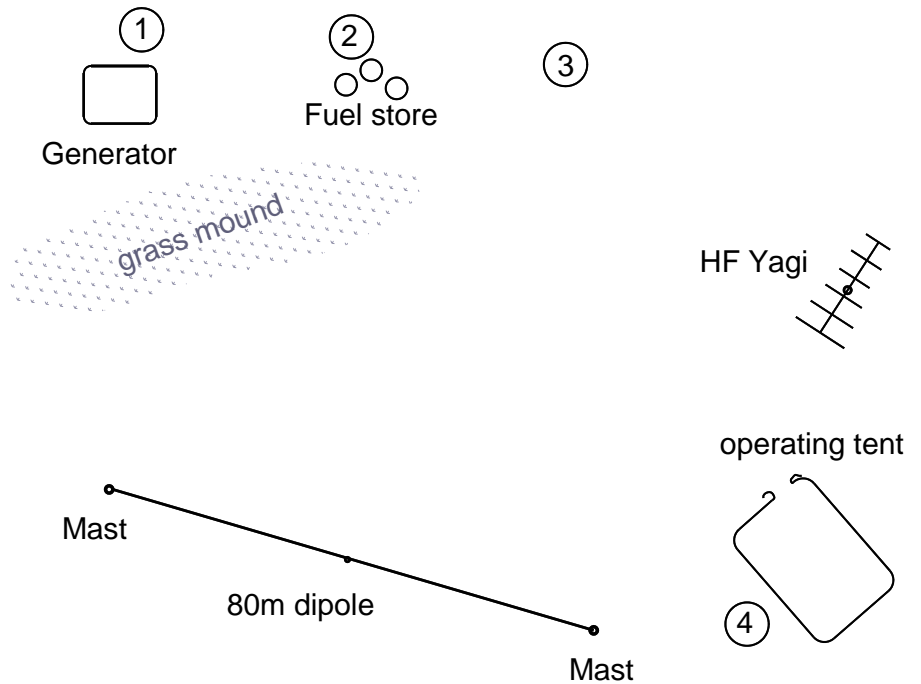

54 The diagram shows part of the circuit of an insulated gate field effect transistor amplifier. The voltage at the gate is measured with a moving coil meter having a full-scale deflection of $100\mu\text{A}$ and a $100\text{k}\Omega$ multiplier resistor, to give a meter of 0-10V. The meter reading will be approximately
9A1, 9A3

- A 1.2V
- B 2V
- C 3.5V
- D 5V

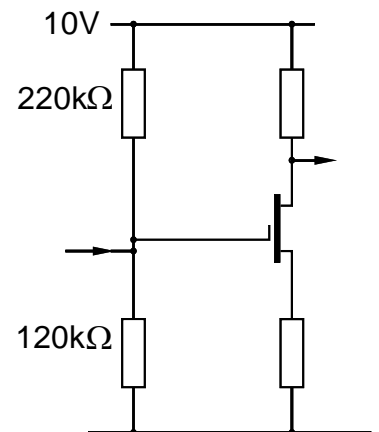

55
9A4, 9A5

An RF signal generator is connected to a receiver for the purposes of calibration of the S-meter as shown in the drawing. An oscilloscope is connected using a BNC T-piece. If the receiver connection is unplugged at point X what, if anything, happens to the oscilloscope trace?

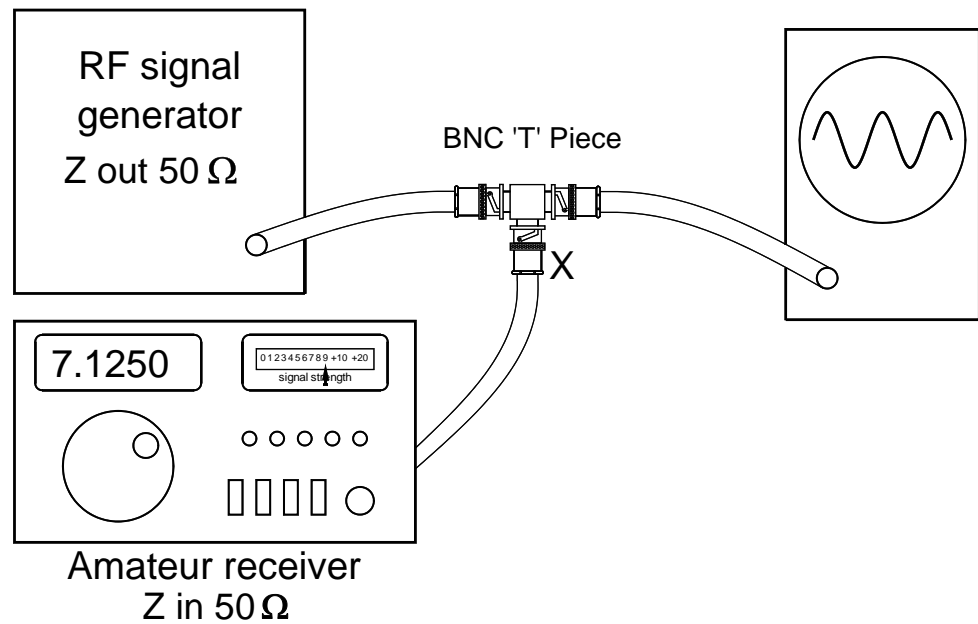

- A Nothing, there is no change.
- B The trace is lost and is a horizontal line.
- C The amplitude is halved.
- D The amplitude is doubled.

56
9A6, 9A7,
9A8, 9A9

The switch marked 'S' in the diagram is likely to have the front panel legend

- A On-Off
- B Hi-Lo
- C In-Out
- D Fwd-Rev.

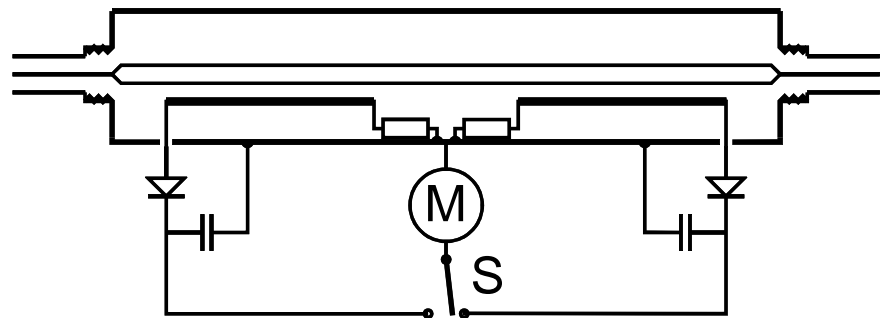

57
9B1

The output of an HF power amplifier is fed to a 50Ω dummy load. The power is being measured using a calibrated oscilloscope which shows 283V peak to peak. What is the power in dBm?

- A 23dBm
- B 53dBm
- C 59dBm
- D 62dBm

58

2A1, 9C1

A 10MHz oscillator uses a very stable capacitor but the inductor has a positive temperature coefficient of 10ppm (parts per million) per degree rise in temperature. What will happen to the frequency for a 10 degree rise in temperature?

- A Frequency decrease by about 500Hz.
- B Frequency decrease by about 1kHz.
- C Frequency increase by about 500Hz.
- D Frequency increase by about 1kHz.

Answer keys

1	2	3	4	5	6	7	8	9
A	C	B	A	C	B	D	B	B
10	11	12	13	14	15	16	17	18
B	D	A	C	C	A	B	C	A
19	20	21	22	23	24	25	26	27
C	A	C	C	A	B	B	B	C
28	29	30	31	32	33	34	35	36
C	A	C	D	B	D	A	C	C
37	38	39	40	41	42	43	44	45
B	B	B	A	C	A	C	D	B
46	47	48	49	50	51	52	53	54
C	D	C	C	C	B	A	C	B
55	56	57	58					
D	D	B	A					